

SyCTRL Electrical Protection

SyCTRL Protection board

- Protection of product under test : OVP, UVP, OCP, ROCP
- Various power range up to 3 kW or more
- Fast reaction time down to 30µs
- Interfaces with standard COTS power supplies (Remote inhibit, sense line,...)
- Physical separation to the Product Under Test
- High impedance measurement lines (>1 MΩ)



Overview

The Protection board secures a DC power line feeding a product under test.

It senses the voltage and current of the power line, filters these values and in case of threshold violation, shuts down the power line by opening the power line via a MOSFET, shorting the power line via a thyristor and generating a "Remote Inhibit" signal to the power supply that feeds the input power line.

The Protection board is mounted in a rear slot of a Chassis.

The Protection board is managed by a standard Decision board which performs the comparison between the values received from the Protection board and the thresholds flashed in the FPGA of the Decision board. The thresholds and filter parameters are user configurable (via secured software).

Downtime optimization

The Protection board embeds its own calibration parameters, minimizing its downtime to the board replacement in case of failure.

Integrated Built-In self test

The Protection board embeds its own built-in self test which gives a clear status of the acquisition lines and of the MOSFET and relay health.

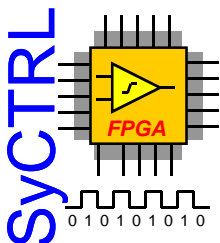
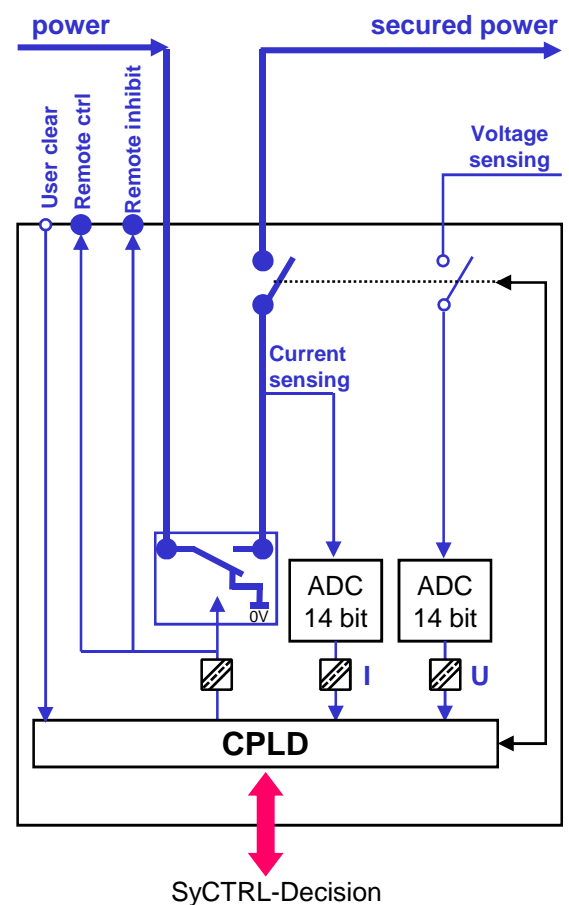

SyCTRL Electrical Protection

Protection features

On power line via a crowbar thyristor, a MOSFET, a schottky diode, a fuse, interfacing the power supply (fault detection and inhibition) and the safety loop.

Protection dead band for inrush filtering for OVP, UVP, OCP and ROCP.

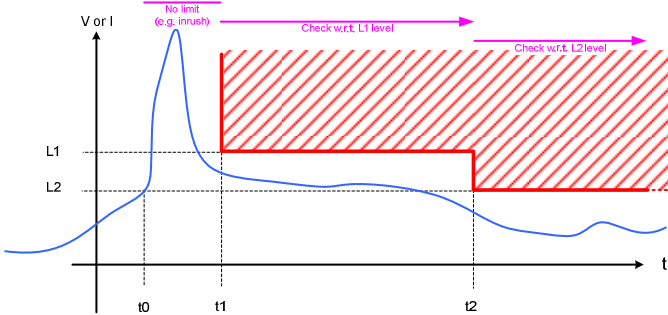

Reaction time down to 30 μ s

Power characteristics

Voltage range

sc210 / sc212 0..130 V
sc211 / sc213 -130..0 V

Current range

sc210 / sc211 0..12 A
sc212 / sc213 0..50 A

Power range

sc210 / sc211 max.1kW
sc212 / sc213 max. 3kW
sc216 + specific electronic over 3kW on request

Power consumption max. 13W

Measurement characteristics

ADC resolution 13 bits + 1 sign bit
Type of ADC Serial
Scan rate 50 kS/s for voltage
25 kS/s for current
Voltage accuracy $\pm 0.05\%$ FSR (*)
Voltage filtering characteristics Low pass $F_c < 2.5$ MHz
Input impedance > 1 M Ω
Current accuracy $\pm 0.5\%$ FSR (*)
Current filtering characteristics Low pass $F_c < 125$ KHz

Physical separation

For sense and power line > 10 M Ω when open

Environmental

Operating environment

Temperature 10 to 40 $^{\circ}$ C
Humidity 40 to 90% noncondensing
Pressure 800 to 1050 mbar

Storage environment

Temperature -10 $^{\circ}$ C to 60 $^{\circ}$ C
Humidity up to 90% noncondensing
Pressure 800 to 1050 mbar

Mechanical

Size

sc210 / sc211 3HU x 8HP x 220mm (*)
sc212 / sc213 3HU x 24HP x 220mm (*)

Weight

sc210 / sc211 370 g
sc212 / sc213 2.1 Kg

Connector

sc210 / sc211 Input 1x D-Sub37 male
sc210 / sc211 Output 1x D-Sub37 female
sc212 / sc213 Input / Output 1x MMC Radial 104

(*) 1 HU = 44.45 mm, 1 HP = 5.08 mm, FSR: Full Scale Range

